

A-A

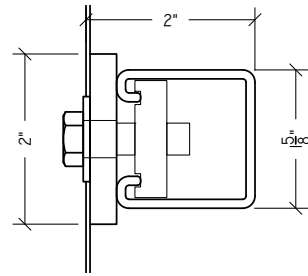

B-B

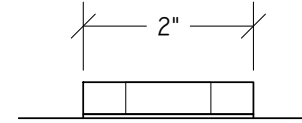

C-C

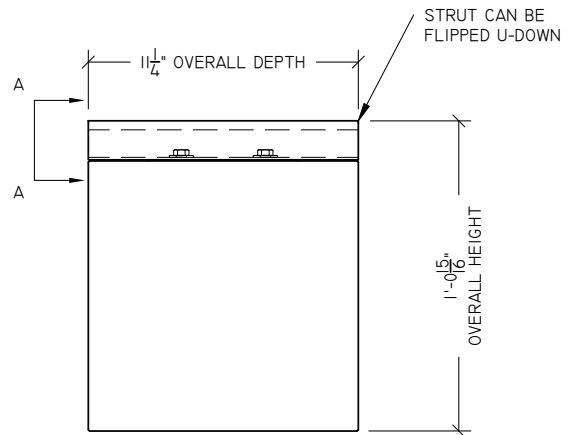

1 TOP MOUNT STRUT  
NOT TO SCALE

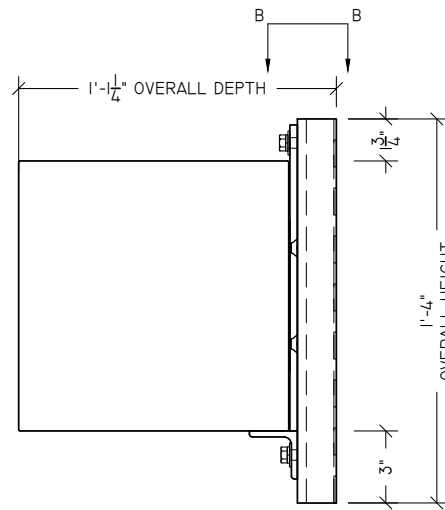

2 REAR MOUNT STRUT  
NOT TO SCALE

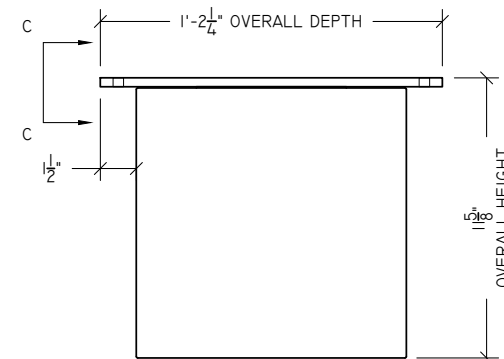

3 TOP MOUNT PLATE  
NOT TO SCALE

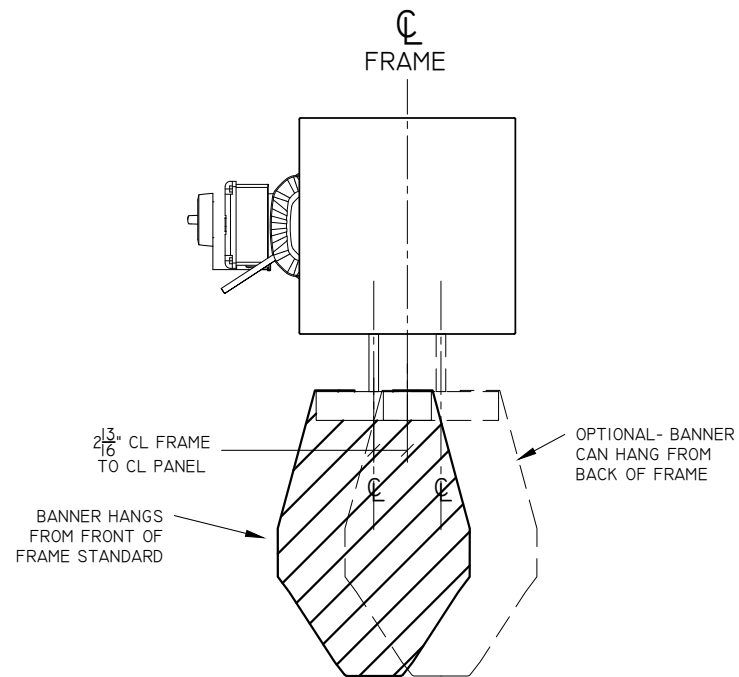

4 STAC OFFSET  
NOT TO SCALE

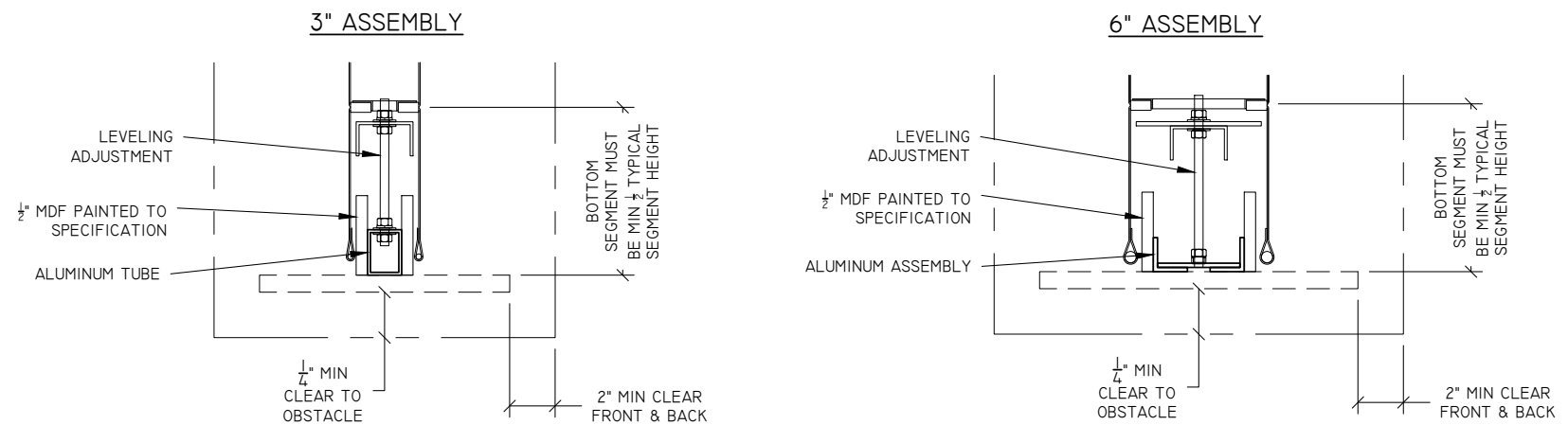

BOTTOM CLOSURE MILLWORK TO BE SPECIFIED BY CLIENT. MUST BE CENTERED AND BALANCED ON THE FABRIC ASSEMBLY TO MAINTAIN PROPER OPERATION OF THE MACHINE.  
ADDED MILWORK WEIGHT CAN NOT EXCEED 3.5 LBS./LINEAR FOOT.

5 BOTTOM CLOSURE  
NOT TO SCALE

8053 POTRANCO ROAD  
SAN ANTONIO, TEXAS 78251  
210-684-0091  
210-684-4557 FAX

TEXAS  
SCENIC  
COMPANY

TSC

PROJECT: ACOUTUNE ACOUSTAC  
SAN ANTONIO, TX

DWG. TITLE: ACOUSTAC BANNER MOUNTING & OPTIONS

ARCHITECT: WJC  
CONSULTANT:  
CONTRACTOR: WJC  
DRAWN BY: WJC  
CHECK BY: WJC  
DATE: 12/13/2023  
JOB NUMBER:

REV: SCALE: AS NOTED

DRAWING NUMBER: VA-1.13

DESCRIPTION:

REV. DATE BY: